

**Lesson #2 Lab Stations: Student Copy**

**Station 1:**

Question: Is it possible to design a working model of the hydrologic cycle by collecting condensation from saltwater?

Materials:

- a hot plate
- 500 ml Beaker
- Tin foil
- salt
- ice cubes
- Large “waste” container

Safety:

- Never turn your back to a heating beaker
- Keep safety goggles on at all times
- Boiling water can burn skin instantly
- Do not move the hot plate until it has fully cooled.

Procedure:

1. Fill the beaker with 200ml of water
2. Add \_\_\_\_ grams of salt to the beaker
3. Place the beaker on the centre of the hotplate and turn it on the high setting
4. Carefully cover the top of the beaker with a piece of tinfoil
5. Place 2-3 ice cubes on the tinfoil, be careful not to let the ice cubes fall into the beaker
6. As the water in the beaker warms, make some observations
7. Once complete, turn off the hotplate, and notify your teacher to pour the water into the waste container

Observations: Make jot notes about what you see. Draw a sketch.

Discussion:

- What happened to the ice cubes?
- What happened to the air between the water and the tinfoil?
- What happened to the tinfoil?
- What happened to the salt?

Conclusion: Answer the original question on the top of the page.

**Station 2 has three mini stations that must be visited.**

a. Can you correctly measure the amount of water in a graduated cylinder?

- Here is How:
  - Make sure the graduated cylinder is flat on the counter
  - Look closely, at eyelevel. There is a U shape that is called a Meniscus.
  - Always measure the amount of water, or other substance, from the bottom of the U shape.

Sources:

<a href="http://hinkhousescience.weebly.com/uploads/1/5/7/4/15746562/9109887_orig.jpg">http://hinkhousescience.weebly.com/uploads/1/5/7/4/15746562/9109887_orig.jpg</a>	<a href="http://images.slideplayer.com/9/2564965/slides/slides_6.jpg">http://images.slideplayer.com/9/2564965/slides/slides_6.jpg</a>	<a href="http://3.bp.blogspot.com/_ZdYujReji4/TOiFUSizOSI/AAAAAAAAAw/e52Hqag8iaQ/s1600/miniscus1.JPG">http://3.bp.blogspot.com/_ZdYujReji4/TOiFUSizOSI/AAAAAAAAAw/e52Hqag8iaQ/s1600/miniscus1.JPG</a>
---	---	---

- Look at the images of the graduated cylinders on the sheet.
  - How much water do you think is in each of the graduated cylinder images?

\_\_\_\_\_

- Measure the water in the three graduated cylinders set out for you:

\_\_\_\_\_

b. Measure the mass of an egg in different substances.

Safety: The eggs have had their shell removed, handle with care.

Directions:

1. Record the original mass of the egg and the type of liquid.
2. Carefully collect the egg out of the beaker, and take it to the scale.
3. Turn on the scale, and zero your scale by pressing the Tare button
4. Record the new mass of the egg in the table below.
5. Carefully return the egg to the beaker
6. Wash your hands.

Complete the following table:

	Substance 1_____	Substance 2_____	Substance 3_____
Mass before			
Mass after			
Same, gained or lost?			

- In which substances did the mass of the egg change? Why?
- Pick one substance and give a likely reason why the mass of the egg changed.
- Predict another substance you think that the same reaction may happen.

c. Question: Is salt water more or less dense than freshwater?

Hypothesis: If \_\_\_\_\_,  
then\_\_\_\_\_.

Procedure:

1. Place an egg in freshwater, and observe what happens.
2. Rise off the egg with distilled water to avoid contamination.
3. Place an egg in saltwater, and observe what happens.

Conclusion: Was your hypothesis correct? Explain.

Discussion:

How could you float the egg in the middle of the beaker (not floating at the top or resting on the bottom)?

### Station 3:

Problem: To determine how much sugar (solute) can be dissolved in cold vs warm vs room temperature water (solvent).

#### Safety:

- Never turn your back to a hot plate.
- Be careful around heated water, as a burn is instant.
- The sugar used is from a chemistry lab, so may have contamination from toxic materials (Do not put lab samples near face).
- Do not let the thermometer rest on the bottom of a heating surface, as it may break.

Variables: What other items need to be controlled, or stay the same? (i.e. amount of water, time, etc.).

#### Materials:

- ring clamp
- hot plate
- Thermometer
- Timer (phone)
- Sugar
- 3 small beakers of the same size
- Cold tap water
- Room temperature water set out the night before
- Ice cubes
- Stirring rod

#### Procedure:

1. Fill each beaker with \_\_\_\_\_ ml of water.
2. Place one beaker on the center of the hotplate and turn it on to the high setting
3. Place 3 ice cubes into the beaker with the cold tap water
4. Carefully measure the temperature of the room temperature water and record your results
5. Start the timer, and slowly add a tablespoon of sugar and stir until dissolved. Stop the timer and record your results.
6. Add as many tablespoons as needed until the sugar does not dissolve anymore. Record the time it took and the number of tablespoons of sugar that were completely dissolved.
7. With the cold-water beaker, follow steps 4, 5 and 6
8. Turn off the hot plate.
9. With the hot water beaker, follow steps 4, 5, and 6. Caution: do not allow the thermometer to touch the bottom of the beaker.

Observations:

	Cold water	Room temperature water	Hot water
Volume of water used			
Water temperature			
# of table spoons of sugar (solute)			
Time for sugar to dissolve			

- Which beaker of water dissolved the most sugar? The least sugar?
- Which beaker of water dissolved the sugar quickly? Which took the longest amount of time?

Discussion:

- Can more solute be dissolved in warm water? Why?
- What do you predict will happen when water cools?
- What do you think happens to solutes in water from summer to winter?
- If you were to do this lab again, what would you do differently?

**Station 4:**

Question: How long does it take to boil room temperature tap water? Salt water? Contaminated water?

Materials:

- 3 beakers of the same size
- Measure \_\_\_\_\_ ml of water of room temperature tap water, salt water, and contaminated water
- Measure the temperature of each and record your results
- Remove the thermometers from the beakers
- Place beakers on the hotplates and as soon as the heat is set to high, turn on the timer (do all 3 at the same time).
- As soon as the water starts to boil, record the time and take the temperature of the water.  
\*Caution: Do NOT place the thermometer on the bottom of the beaker. Remove the thermometer as soon as the temperature is recorded\*

	Tap water	Salt water	Contaminated water
Length of time to boil			
Temperature when boiling			

Conclusion: Answer the question at the start of this lab.

Discussion: Was there a difference as to which type of water boiled faster? Which one? Why?

Predict what may happen if pollution was added to an ecosystem? How would this impact the living things?

Predict what may happen when these same substances freeze.

Last Updated: AUGUST 2017

### Station 5:

Question: How does water respond to different temperatures?

Materials:

- Large glass pan (~15" L x 10" W x 2" H)
- 2x Clamp stand base (remove rod)
- Tea candle
- Ice cubes
- Food colouring

Procedure:

1. Place the clamp stand bases far enough apart to hold the glass pan.
2. Make sure there is enough space under the pan to slide a tea candle under the pan on one side, and an ice cube under the other side.
3. Fill the pan (halfway) with tap water.
4. Carefully light the candle \*Caution\*
5. Drop one drops of food colouring into the pan and watch what happens. Repeat one drop in 3-4 other locations in the pan. Sketch what you see.
6. Very carefully tip the water into a sink \*caution\*

Sketch:

Conclusion (answer the question at the start of the lab):

Discussion:

- Where does the warm and cool water mix?
  
- Predict what would happen if the cool water warmed.

**LAB DIAGRAMS:**

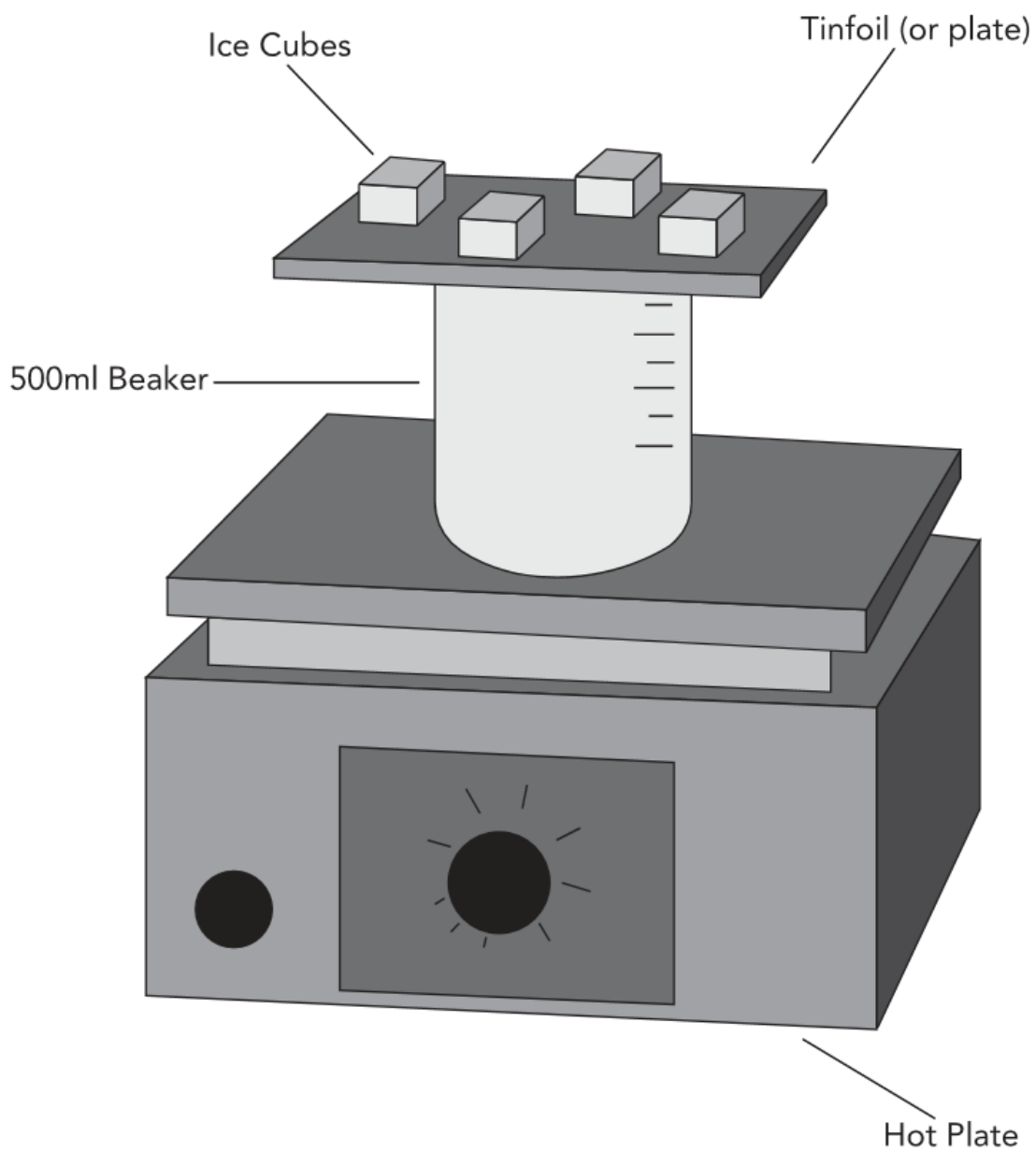



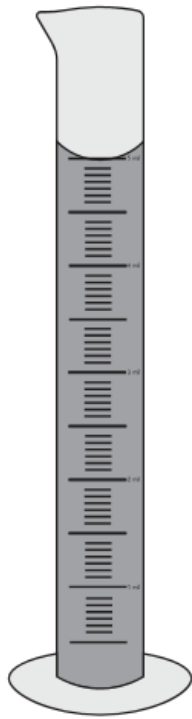

5ml Graduated  
Cylinder

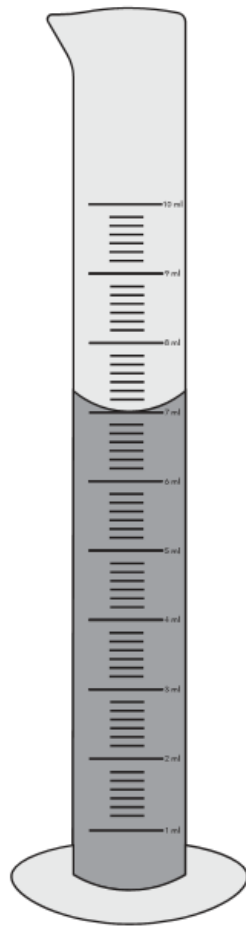

10ml Graduated  
Cylinder

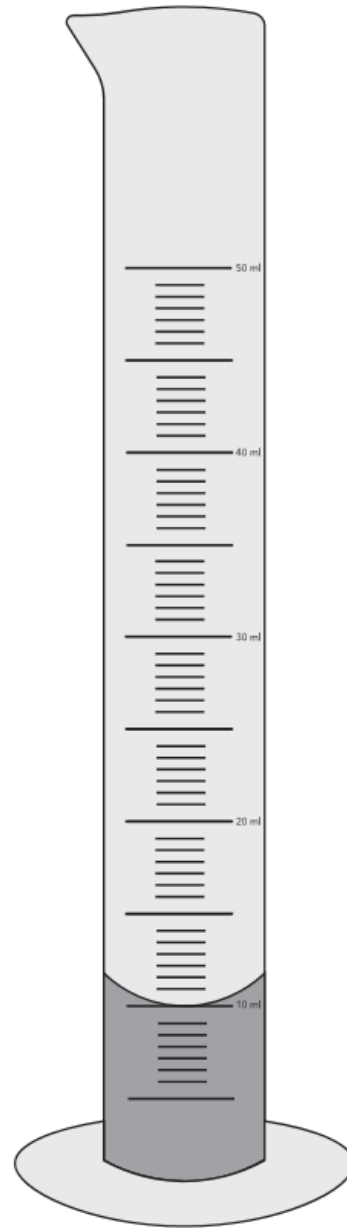

50ml Graduated  
Cylinder

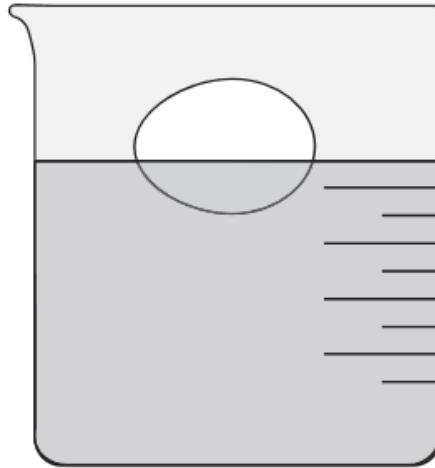

Salt Water

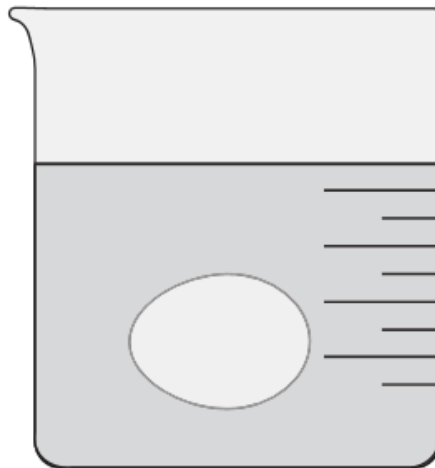

Fresh Water

